

# WESLO®

# CADENCE E-20

Model No. WATL27105.1

Serial No. \_\_\_\_\_

Write the serial number in the space above for future reference.

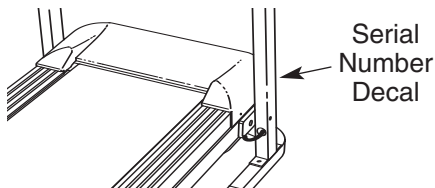

## USER'S MANUAL

### QUESTIONS?

If you have questions, or if there are missing or damaged parts, we will guarantee complete satisfaction through direct assistance from our factory.

**TO AVOID DELAYS, PLEASE CALL DIRECT TO OUR TOLL-FREE CUSTOMER HOT LINE.** The trained technicians on our Customer Hot Line will provide immediate assistance, free of charge to you.

**CUSTOMER HOT LINE:  
800-820-0915**

E-mail:  
newlife@vip.163.com

ICON's Web site:  
www.iconfitness.com

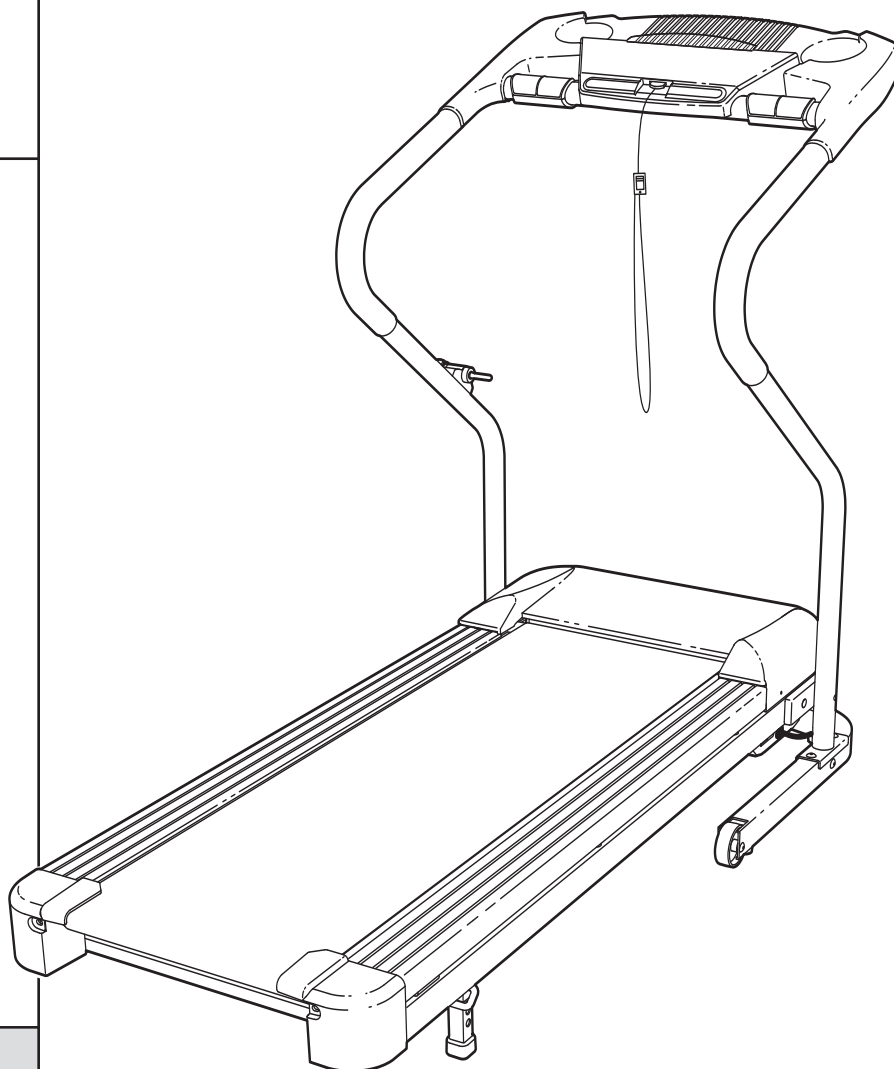

### **⚠ CAUTION**

Read all precautions and instructions in this manual before using this equipment. Save this manual for future reference.

Newlife is an authorized dealer of this treadmill in the territory of mainland China. This treadmill is designed and manufactured by ICON Health & Fitness, Inc.

# WESLO®

# CADENCE E-20

---

## TABLE OF CONTENTS

IMPORTANT PRECAUTIONS .....	3
BEFORE YOU BEGIN .....	5
ASSEMBLY .....	6
OPERATION AND ADJUSTMENT .....	10
HOW TO FOLD AND MOVE THE TREADMILL .....	15
TROUBLESHOOTING .....	17
CONDITIONING GUIDELINES .....	19
ORDERING REPLACEMENT PARTS .....	Back Cover

Note: A PART IDENTIFICATION CHART, an EXPLODED DRAWING, and a PART LIST are attached in the center of this manual.

# IMPORTANT PRECAUTIONS

**⚠ WARNING:** To reduce the risk of burns, fire, electric shock, or injury to persons, read the following important precautions and information before operating the treadmill.

1. It is the responsibility of the owner to ensure that all users of this treadmill are adequately informed of all warnings and precautions.
2. Use the treadmill only as described.
3. Place the treadmill on a level surface, with at least 2.5 m (8 ft.) of clearance behind it and 0.5 m (2 ft.) on each side. Do not place the treadmill on any surface that blocks air openings. To protect the floor or carpet from damage, place a mat under the treadmill.
4. Keep the treadmill indoors, away from moisture and dust. Do not put the treadmill in a garage or covered patio, or near water.
5. Do not operate the treadmill where aerosol products are used or where oxygen is being administered.
6. Keep children under the age of 12 and pets away from the treadmill at all times.
7. The treadmill should not be used by persons weighing more than 115 kg (250 lbs.).
8. Never allow more than one person on the treadmill at a time.
9. Wear appropriate exercise clothes while using the treadmill. Do not wear loose clothes that could become caught in the treadmill. Athletic support clothes are recommended for both men and women. *Always wear athletic shoes. Never use the treadmill with bare feet, wearing only stockings, or in sandals.*
10. When connecting the power cord (see page 10), plug the power cord into an earthed circuit. No other appliance should be on the same circuit. When replacing the fuse, an ASTA approved BS1362 type should be fitted to the fuse carrier. A 13 amp fuse should be used.
11. If an extension cord is needed, use only a 3-conductor, 1mm<sup>2</sup> (14-gauge) cord that is no longer than 1.5 m (5 ft.).
12. Keep the power cord away from heated surfaces.
13. Never move the walking belt while the power is turned off. Do not operate the treadmill if the power cord or plug is damaged, or if the treadmill is not working properly. (See TROUBLESHOOTING if the treadmill is not working properly.)
14. Never start the treadmill while you are standing on the walking belt. Always hold the handrails while using the treadmill.
15. The treadmill is capable of high speeds. Adjust the speed in small increments to avoid sudden jumps in speed.
16. The pulse sensor is not a medical device. Various factors, including your movement, may affect the accuracy of heart rate readings. The pulse sensor is intended only as an exercise aid in determining heart rate trends in general.
17. Never leave the treadmill unattended while it is running. Always remove the key, unplug the power cord, and move the on/off switch to the off position when the treadmill is not in use. (See the drawing on page 5 for the location of the on/off switch.)
18. Do not attempt to raise, lower, or move the treadmill until it is properly assembled. (See ASSEMBLY and HOW TO MOVE THE TREADMILL.) You must be able to safely lift 45 pounds (20 kg) to raise, lower, or move the treadmill.
19. Do not change the incline of the treadmill by placing objects under the treadmill.
20. When folding or moving the treadmill, make sure that the frame is securely held by the lock pin.
21. Inspect and properly tighten all parts of the treadmill regularly.
22. Never drop or insert any object into any opening.

23. **DANGER:** Always unplug the power cord immediately after use, before cleaning the treadmill, and before performing the maintenance and adjustment procedures described in this manual. Never remove the motor hood unless instructed to do so by an authorized service representative. Servicing

other than the procedures in this manual should be performed by an authorized service representative only.

24. This treadmill is intended for in-home use only. Do not use this treadmill in any commercial, rental, or institutional setting.

**⚠ WARNING:** Before beginning this or any exercise program, consult your physician. This is especially important for persons over the age of 35 or persons with pre-existing health problems. Read all instructions before using. Newlife assumes no responsibility for personal injury or property damage sustained by or through the use of this product.

## SAVE THESE INSTRUCTIONS

Caution and warning decals in Chinese have been placed on the treadmill in the locations shown below. English decals with the same information are included. If desired, apply the English decals on top of the Chinese decals. If a decal is missing or illegible, call the telephone number on the front cover of this manual and order a free replacement decal. Apply the decal in the location shown.

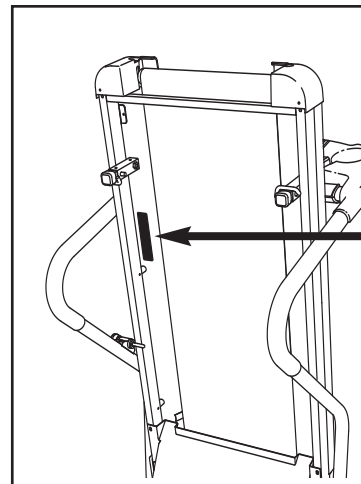
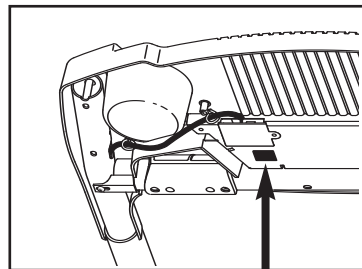

**⚠ WARNING:**

Protect yourself and others from risk of serious injury. Read the user's manual and :

- Stand only on the side rails when starting or stopping treadmill.
- Change speed in small increments.
- Hold handrails to prevent falling, and always wear the safety clip while operating treadmill.
- Stop if you feel faint, dizzy, or short of breath.
- Fully engage storage latch before treadmill is moved or stored.
- Reduce incline to its lowest level before folding treadmill into storage position.

 • Never allow children on or around treadmill.

• Remove key when not in use.

 • Keep clothing, fingers, and hair away from moving belt.

• Never try to adjust or fix the belt while it is moving.

• Always wear athletic shoes while operating treadmill.

# BEFORE YOU BEGIN

Thank you for selecting the new WESLO® E-20 treadmill. The E-20 treadmill offers an impressive array of features designed to help you achieve your fitness goals in the convenience and privacy of your home. And when you're not exercising, the unique E-20 treadmill can be folded up, requiring less than half the floor space of conventional treadmills.

**For your benefit, read this manual carefully before using the treadmill.** If you have questions after read-

ing this manual, see the front cover of this manual. To help us assist you, please note the product model number and serial number before calling. The model number of the treadmill is WATL27105.1. The serial number can be found on a decal attached to the treadmill (see the front cover of this manual for the location).



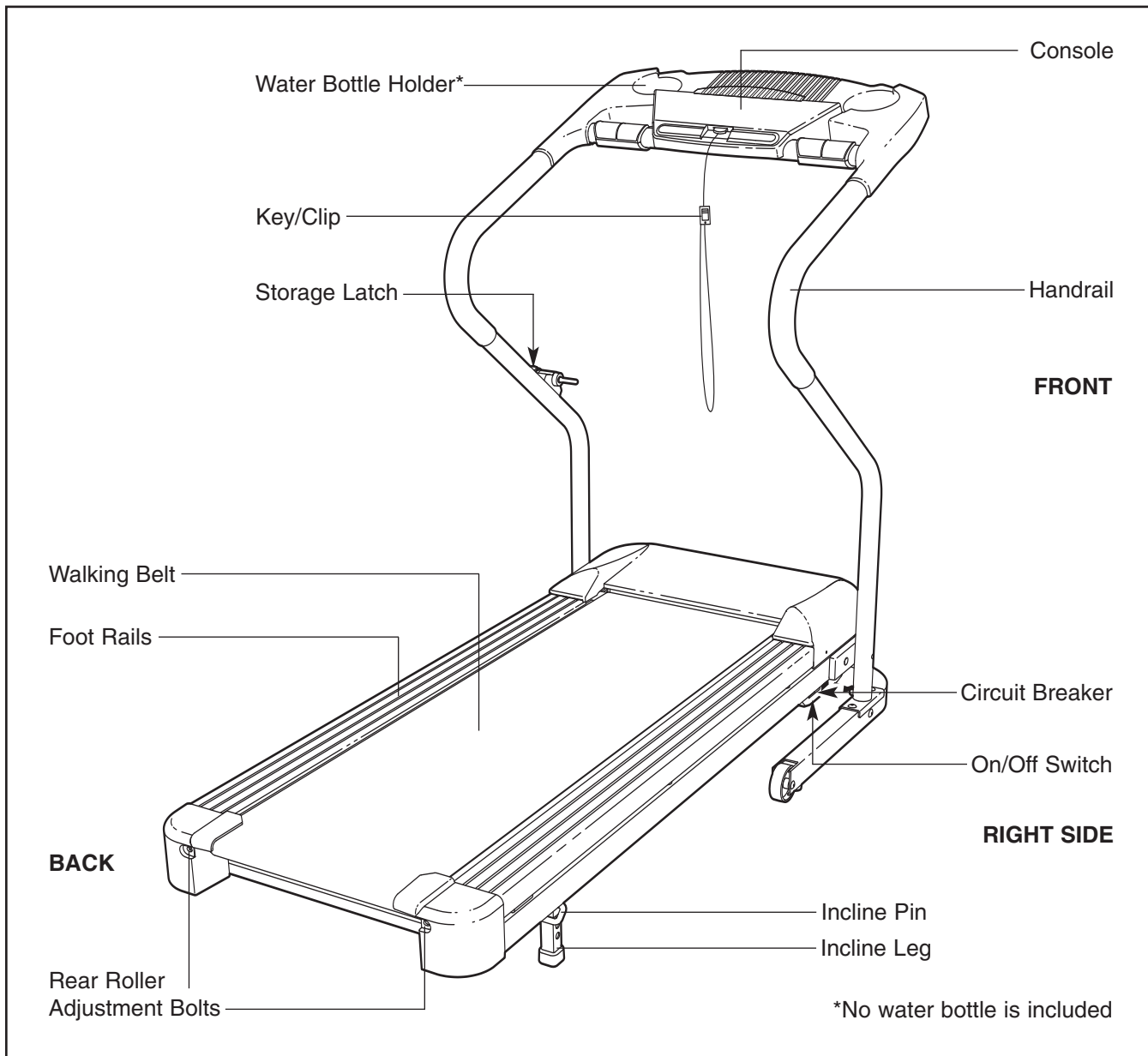

Before reading further, please familiarise yourself with the parts that are labelled in the drawing below.



# ASSEMBLY

**Assembly requires two persons.** Set the treadmill in a cleared area and remove all packing materials; **do not dispose of the packing materials until assembly is completed.**

Note: The underside of the treadmill walking belt is coated with high-performance lubricant. During shipping, a small amount of lubricant may be transferred to the top of the walking belt or the shipping carton. This does not affect treadmill performance. If there is lubricant on top of the walking belt, simply wipe off the lubricant with a soft cloth and a mild, non-abrasive cleaner.

**Assembly requires the included hex keys**  **and your own phillips screwdriver**  **, an adjustable spanner**  **, and needlenose pliers**  .

To identify the assembly hardware, see the **PART IDENTIFICATION CHART** in the center of this manual.

**⚠ WARNING:** Do not plug in the power cord until the treadmill is completely assembled.

1. Orient the Base (46) so the holes for the four Base Pads (63) are on top. Attach the four Base Pads to the Base with the four 1" Tek Screws (5).

Attach the two Wheels (68) to the Base (46) with two 2" Bolts (62) and two 3/8" Nuts (13) as shown. **Do not overtighten the Bolts; the Wheels must be able to turn freely.**

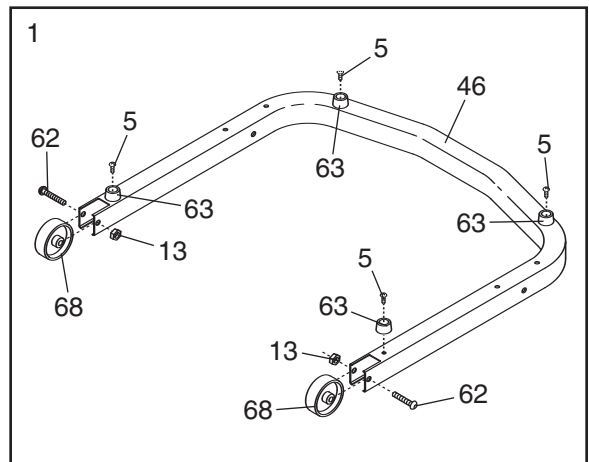

2. Identify the Right Handrail (59), which has a large hole in one side. Have a second person hold the Base (46) in a vertical position, with the Base Pads (63) on the side shown. Next, hold the Right Handrail against the Base so the large hole is in the position shown. Attach the Right Handrail with two 2 1/2" Bolts (65) and two 5/16" Nuts (61), and a 2" Bolt (62) and a 3/8" Nut (13) as shown. **Do not tighten the Bolts yet.**

Attach the Left Handrail (53) to the Base (46) in the same way.

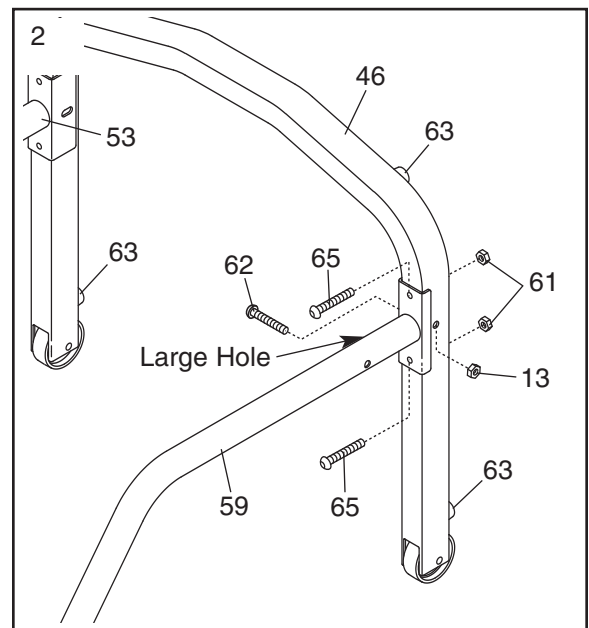

3. Hold a Frame Spacer (27) against the right side of the Frame (79) as shown. Insert a 4" Bolt (70) into the indicated hole in the Frame Spacer and the Frame. Next, tighten a 3/4" Tek Screw (3) into the Frame Spacer and the Frame. Then, remove the Bolt. Repeat this step on the other side of the Frame.

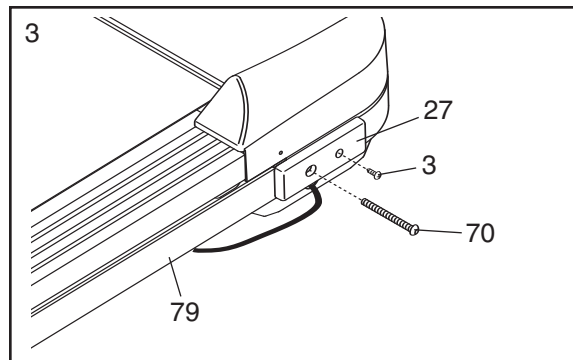

4. Raise the Right Handrail (59) and the Left Handrail (not shown) so the Base (46) is flat on the floor. Next, position the Handrails near the Frame (79).

Locate the Wire Harness (60). Next, locate the long piece of tape in the large hole near the lower end of the Right Handrail (59). Wrap the end of the tape around the end of the Wire Harness as shown in drawing 4a. Then, tighten the included plastic tie securely around the tape and the Wire Harness as shown in drawing 4b.

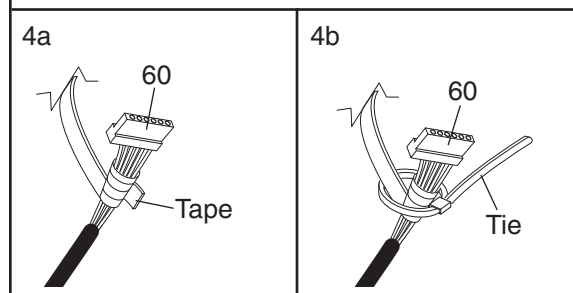
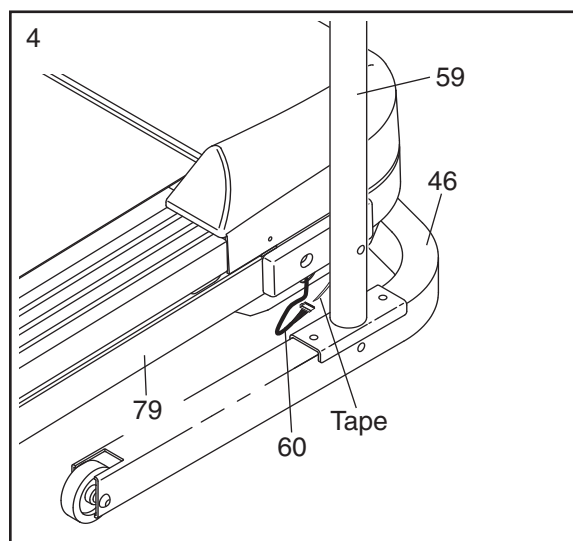

5. With the help of a second person, lift and hold the Frame (79) between the Right Handrail (59) and the Left Handrail (not shown). Finger tighten a 4" Bolt (70) with a 3/8" Washer (66) and a 3/8" Star Washer (29) through the Right Handrail and the Frame Spacer (27) into the Frame. **Do not tighten the Bolt yet.** Repeat this step on the left side of the treadmill.

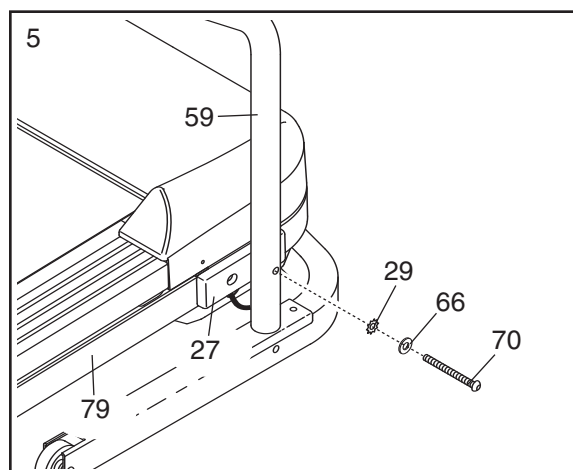



- Carefully pull the opposite end of the tape to pull the Wire Harness (60) up through the Right Handrail (59) and out of the hole in the side of the Right Handrail.

Remove the tape from the Wire Harness (60).

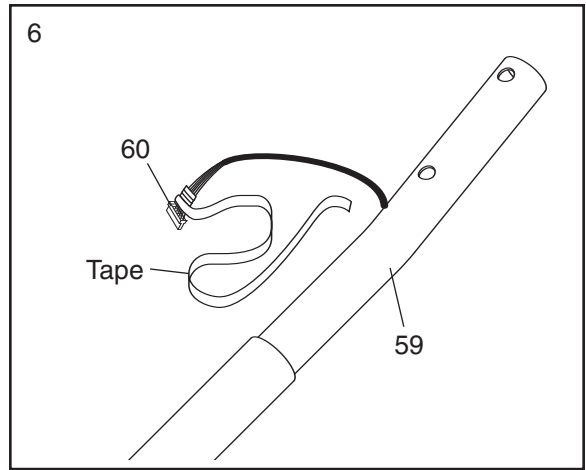

- Orient the Crossbar (91) with the large hole at the right of the smaller hole as shown. Set the Crossbar against the Handrails (53, 59) with the brackets on the Crossbar aligned with the two small holes in each Handrail. Attach the Crossbar with two Crossbar Star Washers (93) and two Crossbar Screws (92). **Do not tighten the Crossbar Screws yet.**

With the help of a second person, hold the console assembly near the Crossbar (91). Connect the pulse wire from the Crossbar to the pulse wire from the console assembly. **The connectors should slide easily into each other and snap into place.** If they do not slide easily and snap into place, turn a connector and then insert it.

Insert the ground wire through the two plastic ties shown in step 8. Attach the end of the ground wire to the small hole in the side of the Right Handrail (59) with a Silver Ground Screw (69).

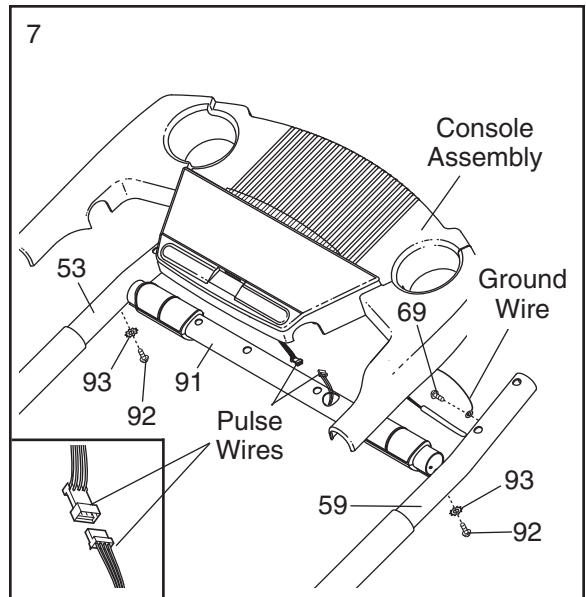

- Place the Console Base (52) on the Crossbar (91), Right Handrail (59) and the Left Handrail (not shown). **Be careful not to pinch any wires.** Attach the Console Base with four 3/4" Screws (2) (only two Screws are shown). **Do not overtighten the Screws.**

Insert the Wire Harness (60) through the two indicated plastic ties on the Console Base (52). Next, **touch the Right Handrail (59) to discharge any static.** See the inset drawing. Insert the connector on the end of the Wire Harness into the red socket beneath the console. **The connector should slide easily into the socket and snap into place.** If the connector does not slide easily and snap into place, turn the connector and then insert it.

Make sure that the connector and wire appear as shown in the inset drawing. **IF THE CONNECTORS ARE NOT INSERTED PROPERLY, THE CONSOLE MAY BE DAMAGED WHEN THE POWER IS TURNED ON.**

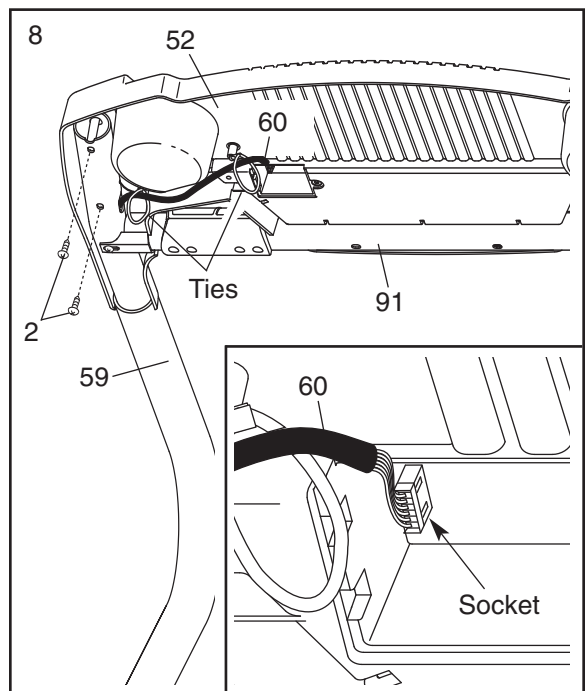



9. Insert the excess Wire Harness (60) into the large hole in the side of the Right Handrail (59). **Securely tighten the plastic ties on the bottom of the Console Base (52) to prevent the Wire Harness from slipping.** Then, cut off the ends of the plastic ties.

Route the Wire Harness (60) through the indicated opening in the Console Base (52). Attach the Wire Cover (54) to the Console Base with a 1/2" Silver Screw (90).

Tighten two 3/4" Screws (2) into the Console Base (52). Tighten the two Crossbar Screws (92).

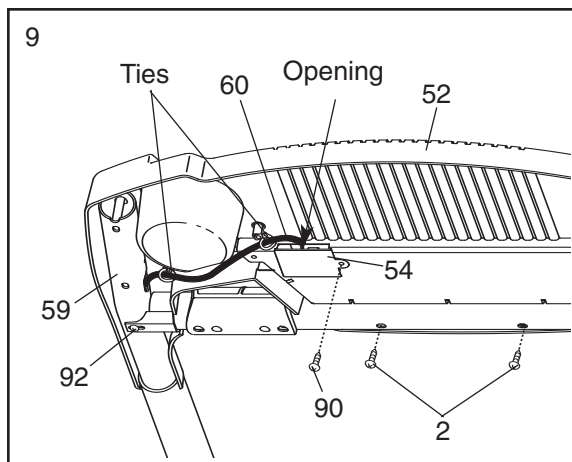

10. Lower the Handrails (53, 59) until they are touching the floor.

See 10a. Position the Handrails (53, 59) so the treadmill Frame (79) is centered between them.

Firmly tighten the four 2 1/2" Bolts (65), the two 2" Bolts (62), and the two 4" Bolts (70). **Be careful not to over-tighten the Bolts.**

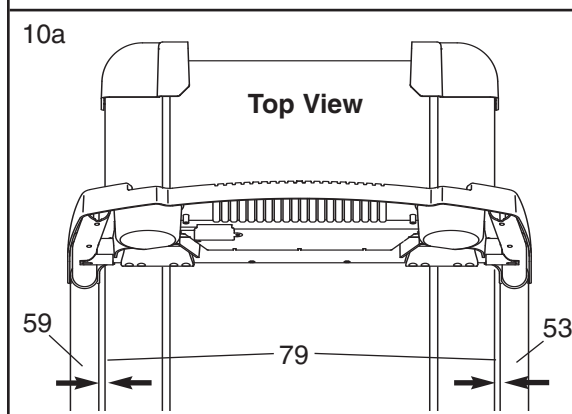
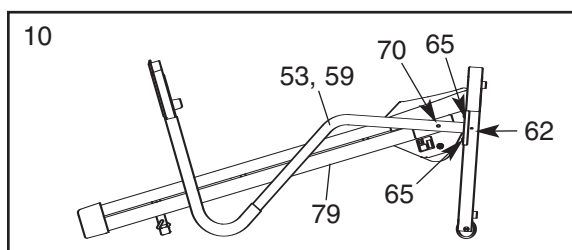

11. Orient the Latch Housing (48) so the large hole is on the indicated side. Attach the Latch Housing to the Left Handrail (53) with two 3/4" Screws (2); **start both Latch Screws and then tighten them.**

Remove the knob from the pin. Make sure that the collar and the spring are on the pin. (Note: If there are two collars, place one on each side of the spring.) Next, insert the pin into the Latch Housing (48). Then, tighten the knob back onto the pin.

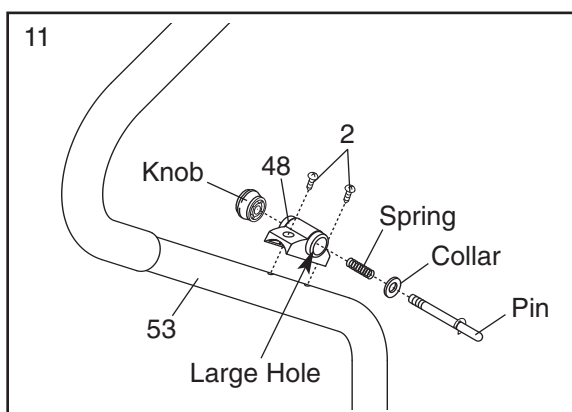

12. **Make sure that all parts used in assembly are properly tightened before you use the treadmill.** Keep the included hex key in a secure place; the hex key is used to adjust the walking belt (see page 18). To protect the floor or carpet, place a mat under the treadmill.

# OPERATION AND ADJUSTMENT

## THE PRE-LUBRICATED WALKING BELT

Your treadmill features a walking belt coated with high-performance lubricant. **IMPORTANT: Never apply silicone spray or other substances to the walking belt or the walking platform. Such substances will deteriorate the walking belt and cause excessive wear.**

## HOW TO PLUG IN THE POWER CORD

**This product must be earthed.** If it should malfunction or break down, earthing provides a path of least resistance for electric current to reduce the risk of electric shock. This product is equipped with a power cord having an equipment-earthing conductor and an earthing plug. **Important: If the power cord is damaged, it must be replaced with a manufacturer-recommended power cord.**

See drawing 1. Plug the indicated end of the power cord into the socket on the treadmill.

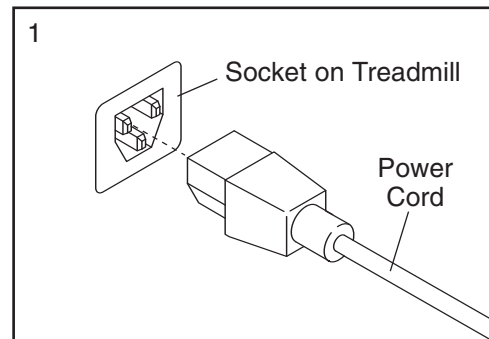

See drawing 2. Plug the power cord into an appropriate outlet that is properly installed and earthed in accordance with all local codes and ordinances. **Important: The treadmill is not compatible with GFCI-equipped outlets.**

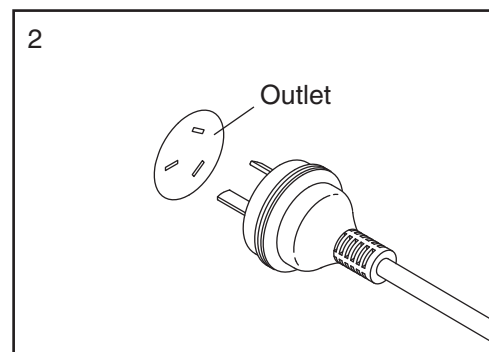

**⚠ DANGER:** Improper connection of the equipment-earthing conductor can result in an increased risk of electric shock. Check with a qualified electrician or serviceman if you are in doubt as to whether the product is properly earthed. Do not modify the plug provided with the product—if it will not fit the outlet, have a proper outlet installed by a qualified electrician.

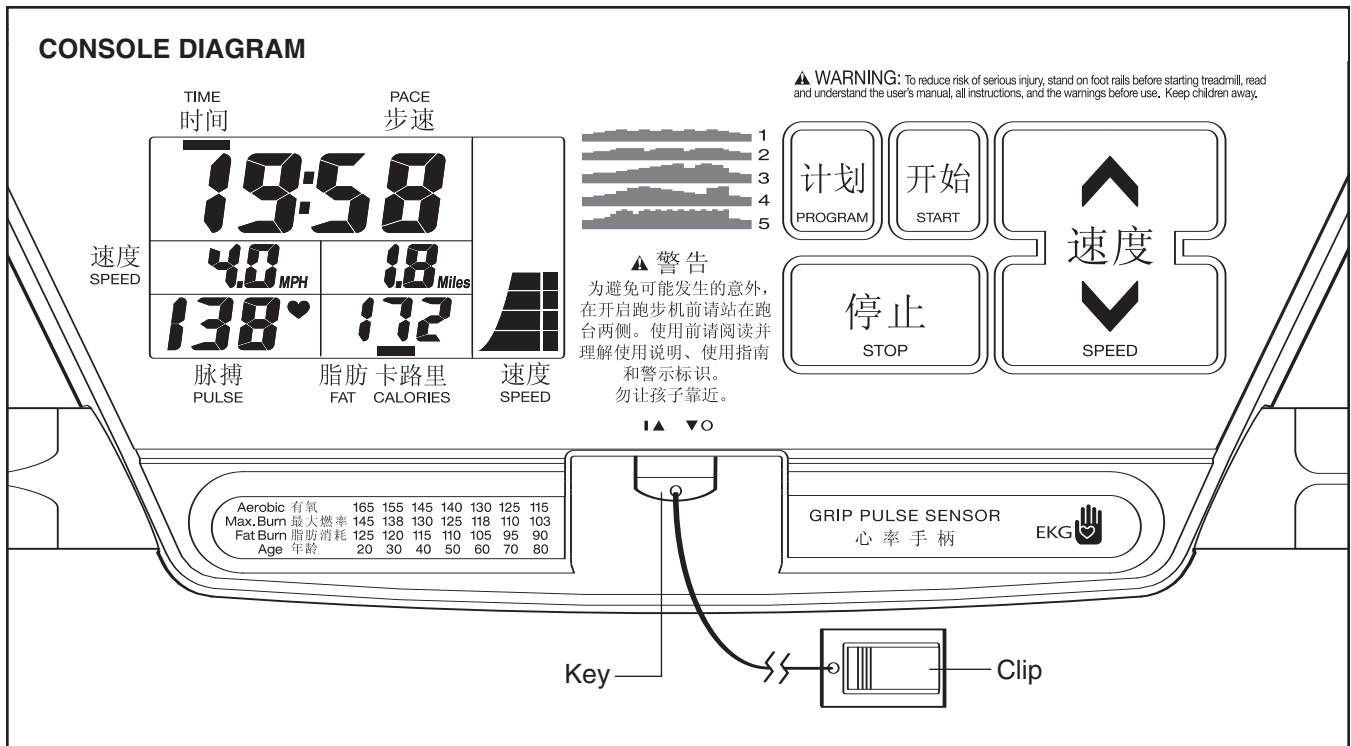

## FEATURES OF THE CONSOLE

The treadmill console offers a selection of features designed to make your workouts more effective. When the manual mode of the console is selected, the speed and incline of the treadmill can be changed with the touch of a button. As you exercise, the console will display continuous exercise feedback. You can even measure your heart rate using the built-in pulse sensor.

Five speed programs are also offered. Each program automatically controls the speed of the treadmill as it guides you through an effective workout.

**To use the manual mode of the console**, follow the steps beginning on page 12. **To use a speed program**, see page 13.

Note: If there is a sheet of clear plastic on the console, remove the plastic. To prevent damage to the walking platform, always wear clean athletic shoes while using the treadmill. The first time the treadmill is used, regularly inspect the alignment of the walking belt, and centre the walking belt if necessary (see page 18).

## HOW TO TURN ON THE POWER

Plug in the power cord (see page 10).

Locate the on/off switch on the treadmill frame near the power cord. Make sure that the switch is in the "on" position.

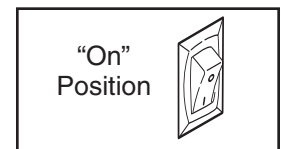

Next, stand on the foot rails of the treadmill. Find the clip attached to the key (see the drawing at the top of this page) and attach the clip securely to the waistband of your clothes. Then, insert the key into the console. After a moment, the display will light. **Test the clip by carefully taking a few steps backward until the key is pulled from the console. If the key is not pulled from the console, adjust the position of the clip as needed.**

### 1 Insert the key into the console.

See HOW TO TURN ON THE POWER on page 11.

### 2 Select the manual mode.

When the key is inserted, the manual mode will be selected; three zeros will appear in the Time/Pace zone of the display. If a program has been selected, remove the key and then reinsert it to select the manual mode.



### 3 Press the Start button or the Speed increase button to start the walking belt.

When the Start button or the Speed increase button is pressed, the walking belt will begin to move at 1 mph. As you exercise, change the speed of the walking belt as desired by pressing the Speed increase and decrease buttons. Each time a button is pressed, the speed setting will change by 0.1 mph; if a button is held down, the speed setting will change in increments of 0.5 mph.

**Note: The console can display speed and distance in either miles or kilometers (see step 5 on this page). For simplicity, all instructions in this section refer to miles.**

To stop the walking belt, press the Stop button. The Time/Pace zone of the display will begin to flash. To restart the walking belt, press the Start button or the Speed increase button.

### 4 Follow your progress with the display.

The Time/Pace zone of the display will show the elapsed time and your pace (pace is shown in minutes per mile). Note: When a program is selected, the display will show the time remaining in the program instead of the elapsed time.



The Speed zone of the display will show the speed of the walking belt.

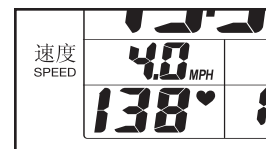

The Distance zone of the display will show the distance you have walked or run.

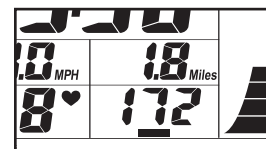

The Fat/Calories zone of the display will show the approximate numbers of *calories* and *fat calories* you have burned during your workout (see FAT BURNING on page 19).

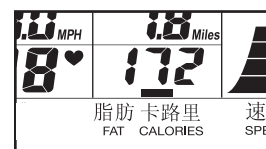

The Pulse zone of the display will show your heart rate when you use the handgrip pulse sensor.

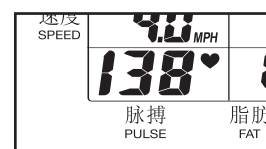

The speed bar in the right side of the display will increase or decrease in height as the speed of the walking belt increases or decreases.



### 5 Access the information mode if desired.

The console can display speed and distance in either miles or kilometers. To change the unit of measurement, select the information mode by holding down the Stop button, inserting the key into the console, and then releasing the Stop button. The following information will be shown:

An "E" (for English miles) or an "M" (for metric kilometers) will appear in the Fat/Calories zone of the display. Press the Speed increase button to change the unit of measurement.



The Time/Pace zone of the display will show the total number of hours that the treadmill has been used.

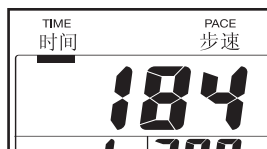

The Distance zone of the display will show the total number of miles that the walking belt has moved.

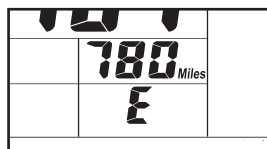

**IMPORTANT:** If a “d” appears in the Speed zone of the display, the console is in the “demo” mode. This mode is intended to be used only when a treadmill is displayed in a store. When the console is in the demo mode, the power cord can be plugged in, the key can be removed from the console, and the indicators in the display will automatically appear in a preset sequence. The buttons on the console will not operate. **If a “d” appears when the information mode is selected, press the Speed decrease button so the “d” disappears.**

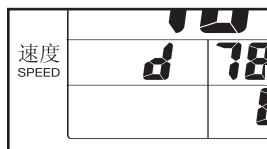

To exit the information mode, remove the key from the console.

## 6 Measure your heart rate, if desired.

Before using the handgrip pulse sensor, remove the sheets of clear plastic from the metal contacts. In addition, make sure that your hands are clean.

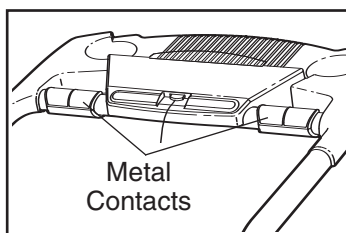

To measure your heart rate, **stand on the foot rails** and hold the metal contacts on the pulse handgrips—**avoid moving your hands**. When your pulse is detected, the heart symbol in the Pulse zone of the display will begin to flash each time your heart beats, one or two dashes will

appear, and then your heart rate will be shown. For the most accurate heart rate reading, continue to hold the contacts for about 15 seconds.

If the displayed heart rate appears to be too high or too low, or if your heart rate is not displayed, lift your hands off the metal contacts for a few seconds. Then, place your hands on the metal contacts as described above. Remember to stand still while measuring your heart rate.

## 7 When you are finished exercising, remove the key.

Step onto the foot rails and press the Stop button. Next, remove the key from the console and put it in a secure place. **Note: If the display remains lit after the key is removed, the console is in the demo mode. See step 5 on page 12 and turn off the demo mode.**

**When you are finished using the treadmill, switch the on/off switch to the “off” position and unplug the power cord.**

## HOW TO USE A SPEED PROGRAM

### 1 Insert the key fully into the console.

See HOW TO TURN ON THE POWER on page 11.

### 2 Select a speed program.

To select a speed program, press the Program button repeatedly until the number 1, 2, 3, 4, or 5 appears in the Speed zone of the display. When a speed program is selected, the Time/Pace zone will show how long the program will last, and the Speed zone will flash the maximum speed setting of the program for a few seconds.



**3** Press the Start button or the Speed increase button to start the program.

A moment after the button is pressed, the treadmill will automatically adjust to the first speed setting for the program. Hold the handrails and begin walking.

Each program is divided into 30 one-minute periods. One speed setting is programmed for each period. Note: The same speed setting may be programmed for two or more consecutive periods.

When only three seconds remain in the first period of the program, a series of tones will sound. If a different speed setting is programmed for the upcoming period, the Speed zone of the display will flash. The treadmill will then automatically adjust to the speed setting for the second period.

The program will continue until no time remains in the Time/Pace zone of the display. The walking belt will then slow to a stop.

Note: If the speed setting for the current period is too high or too low, you can manually override the setting by pressing the Speed buttons.

**Important: When the current period of the program ends, the treadmill will automatically adjust to the speed setting for the next period.**

To stop the program, press the Stop button. The Time/Pace zone of the display will begin to flash. To restart the program, press the Start button or the Speed increase button. The walking belt will begin to move at 1 mph. When the next period of the programs begins, the walking belt will change to the speed setting for the next period. To end the program, press the Stop button, remove the key, and then reinsert the key.

**4** Follow your progress with the display.

See step 4 on page 12.

**5** Measure your heart rate if desired.

See step 6 on page 13.

**6** When the program ends, remove the key from the console.

When the program ends, see step 7 on page 13.

**HOW TO CHANGE THE INCLINE OF THE TREADMILL**

To vary the intensity of your exercise, the incline of the treadmill can be changed; there are four incline levels. **Before changing the incline, remove the key and unplug the power cord.** Next, fold the treadmill to the storage position (see HOW TO FOLD THE TREADMILL FOR STORAGE on page 15).

To change the incline, first remove the incline pin from one of the incline legs as shown at the right. Next, adjust the incline leg to the desired height, and fully reinsert the incline pin. Make sure that the incline pin is in the "locked" position shown in the inset drawing.

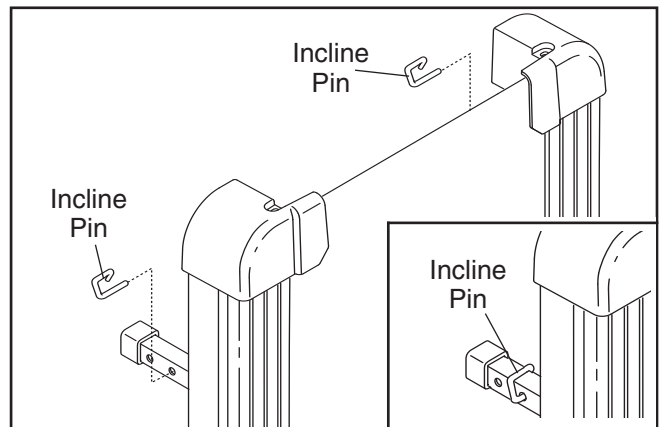

Adjust the other incline leg in the same way. **Make sure that both incline pins are inserted from the direction shown in the drawing.**

**CAUTION: Before using the treadmill, make sure that both incline legs are at the same height. Do not use the treadmill with the incline pins removed.** After you have adjusted the incline legs, lower the treadmill (see HOW TO LOWER THE TREADMILL FOR USE on page 16).

# HOW TO FOLD AND MOVE THE TREADMILL

## HOW TO FOLD THE TREADMILL FOR STORAGE

Before folding the treadmill, unplug the power cord.

**CAUTION: You must be able to safely lift 45 pounds (20 kg) to raise, lower or move the treadmill.**

1. Hold the treadmill with your hands in the location shown by the arrow at the right. **To decrease the possibility of injury, bend your legs and keep your back straight. As you raise the frame, make sure to lift with your legs rather than your back.** Raise the frame about halfway to the vertical position.

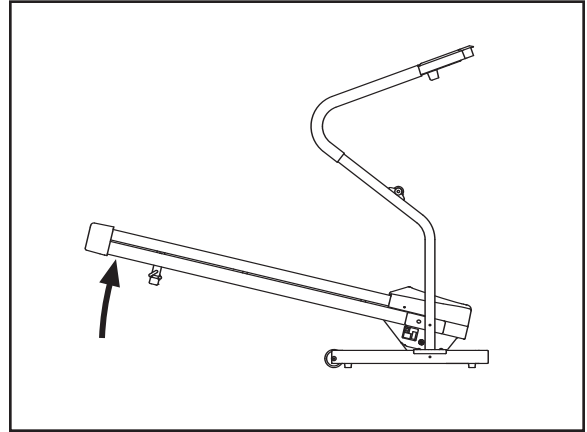

2. Move your right hand to the position shown and hold the treadmill firmly. Using your left hand, pull the lock knob to the left and hold it. Raise the frame until it passes the lock pin. Slowly release the lock knob. **Make sure that the frame is securely held by the lock pin.**

**To protect the floor or carpet from damage, place a mat under the treadmill. Keep the treadmill out of direct sunlight. Do not leave the treadmill in the storage position in temperatures above 30° C (85° F).**

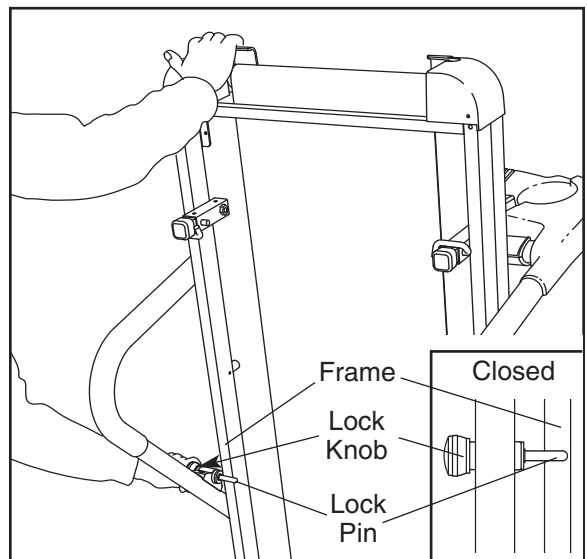

## HOW TO MOVE THE TREADMILL

Before moving the treadmill, convert the treadmill to the storage position as described above. **Make sure that the frame is securely held by the lock pin.**

1. Hold the handrails, and place one foot against one of the wheels.
2. Tilt the treadmill back until it rolls freely on the wheels. Carefully move the treadmill to the desired location. **To reduce the risk of injury, use extreme caution while moving the treadmill. Do not move the treadmill over an uneven surface.**
3. Place one foot against one of the wheels, and carefully lower the treadmill to the storage position.

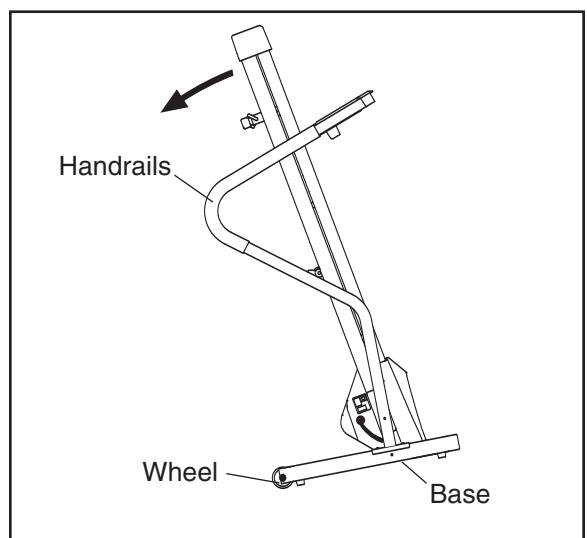



## HOW TO LOWER THE TREADMILL FOR USE

1. Hold the upper end of the treadmill with your right hand as shown. Using your left hand, pull the lock knob to the left and hold it. Pivot the frame down until it is past the lock pin. Slowly release the lock knob.

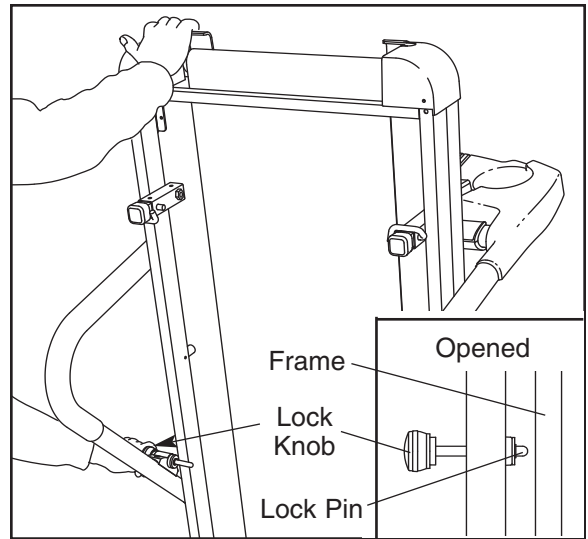

2. Hold the frame firmly with both hands, and lower the frame to the floor. **Do not drop the frame to the floor. To decrease the possibility of injury, bend your legs and keep your back straight.**

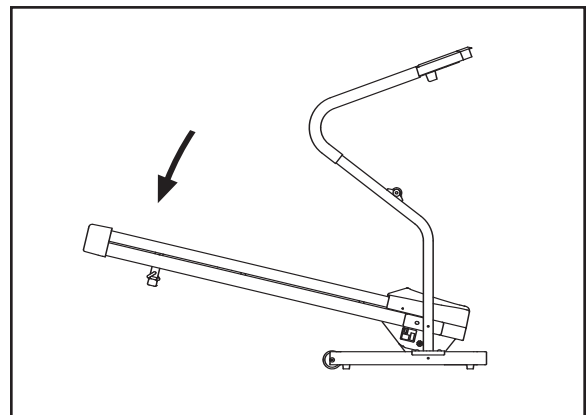

# TROUBLESHOOTING

Most treadmill problems can be solved by following the steps below. Find the symptom that applies, and follow the steps listed. If further assistance is needed, please see the front cover of this manual.

**PROBLEM: The power does not turn on**

**SOLUTION:** a. Make sure that the power cord is plugged into a properly earthed outlet (see page 10). If an extension cord is needed, use only a 3-conductor, 1mm<sup>2</sup> (14-gauge) cord that is no longer than 1.5 m (5 ft.). **IMPORTANT: The treadmill is not compatible with GFCI-equipped outlets.**

b. After the power cord has been plugged in, make sure that the key is fully inserted into the console.

c. Check the circuit breaker located on the treadmill near the power cord. If the switch protrudes as shown, the circuit breaker has tripped. To reset the circuit breaker, wait for five minutes and then press the switch back in.

d. Check the on/off switch located on the frame near the power cord. The switch must be in the “on” position.

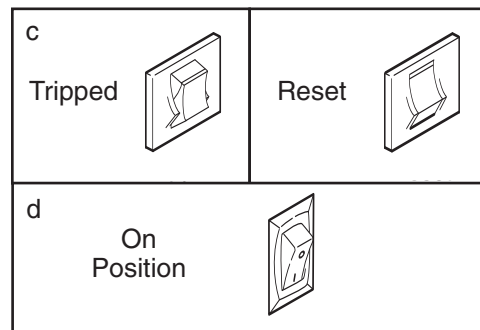

**PROBLEM: The power turns off during use**

**SOLUTION:** a. Check the circuit breaker located on the treadmill frame near the power cord (see c. above). If the circuit breaker has tripped, wait for five minutes and then press the switch back in.

b. Make sure that the power cord is plugged in. If the power cord is plugged in, unplug it, wait for five minutes, and then plug it back in.

c. Remove the key from the console. Reinsert the key fully into the console.

d. Make sure that the on/off switch is in the “on” position (see d. above).

e. If the treadmill still will not run, please see the front cover of this manual.

**PROBLEM: The displays of the console do not function properly**

**SOLUTION:** a. Remove the key from the console and **UNPLUG THE POWER CORD**. Remove the screws from the hood. Carefully remove the hood. Locate the Reed Switch (76) and the Magnet (47) on the left side of the Pulley (77). Turn the Pulley until the Magnet is aligned with the Reed Switch. **Make sure that the gap between the Magnet and the Reed Switch is about 1/8”**. If necessary, loosen the Screw (3), move the Reed Switch slightly, and then retighten the Screw. Reattach the hood, and run the treadmill for a few minutes to check for a correct speed reading.

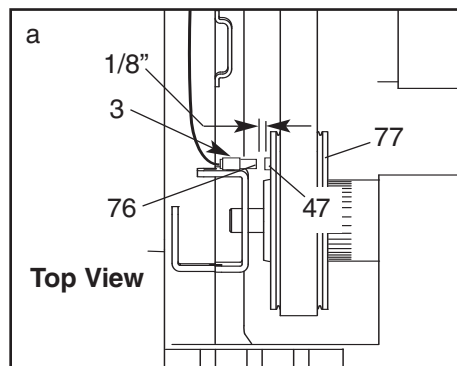

**PROBLEM: The walking belt slows when walked on**

**SOLUTION:** a. If an extension cord is needed, use only a 3-conductor, 1mm<sup>2</sup> (14-gauge) cord that is no longer than 1.5 m (5 ft.).

b. If the walking belt is overtightened, treadmill performance may decrease and the walking belt may become damaged. Remove the key and **UNPLUG THE POWER CORD**. Using the hex key, turn both rear roller bolts counterclockwise, 1/4 of a turn. When the walking belt is properly tightened, you should be able to lift each edge of the walking belt 2 to 3 inches off the walking platform. Be careful to keep the walking belt centered. Then, plug in the power cord, insert the key, and run the treadmill for a few minutes. Repeat until the walking belt is properly tightened.

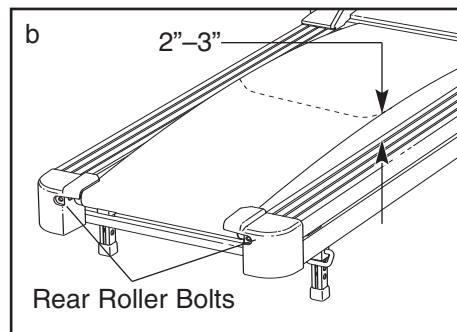

c. If the walking belt still slows when walked on, please see the front cover of this manual.

**PROBLEM: The walking belt is off-center or slips when walked on**

**SOLUTION:** a. If the walking belt is off-center, first remove the key and **UNPLUG THE POWER CORD**. **If the walking belt has shifted to the left**, use the hex key to turn the left rear roller bolt clockwise 1/2 of a turn; **if the walking belt has shifted to the right**, turn the bolt counterclockwise 1/2 of a turn. Be careful not to overtighten the walking belt. Then, plug in the power cord, insert the key, and run the treadmill for a few minutes. Repeat until the walking belt is centered.

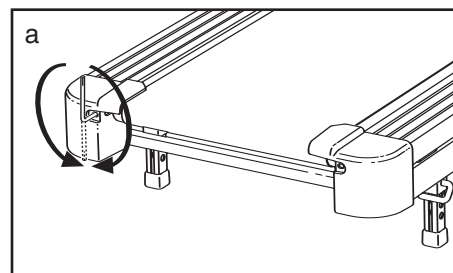

b. If the walking belt slips when walked on, first remove the key and **UNPLUG THE POWER CORD**. Using the hex key, turn both rear roller bolts clockwise, 1/4 of a turn. When the walking belt is correctly tightened, you should be able to lift each edge of the walking belt 2 to 3 inches off the walking platform. Be careful to keep the walking belt centered. Then, plug in the power cord, insert the key, and carefully walk on the treadmill for a few minutes. Repeat until the walking belt is properly tightened.

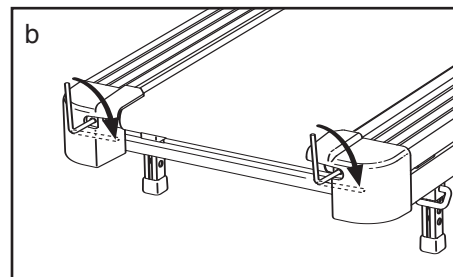

# CONDITIONING GUIDELINES

**⚠️ WARNING:** Before beginning this or any exercise program, consult your physician. This is especially important for individuals over the age of 35 or individuals with pre-existing health problems.

The pulse sensor is not a medical device. Various factors, including your movement, may affect the accuracy of heart rate readings. The sensor is intended only as an exercise aid in determining heart rate trends in general.

The following guidelines will help you to plan your exercise program. For more detailed exercise information, obtain a reputable book or consult your physician.

## EXERCISE INTENSITY

Whether your goal is to burn fat or to strengthen your cardiovascular system, the key to achieving the desired results is to exercise with the proper intensity. The proper intensity level can be found by using your heart rate as a guide. The chart below shows recommended heart rates for fat burning and aerobic exercise.

HEART RATE TRAINING ZONES							
AEROBIC	165	155	145	140	130	125	115
MAX FAT BURN	145	138	130	125	118	110	103
FAT BURN	125	120	115	110	105	95	90
Age	20	30	40	50	60	70	80

To find the proper heart rate for you, first find your age near the bottom of the chart (ages are rounded off to the nearest ten years). Next, find the three numbers above your age. The three numbers define your “training zone.” The lower two numbers are recommended heart rates for fat burning; the higher number is the recommended heart rate for aerobic exercise.

## Fat Burning

To burn fat effectively, you must exercise at a relatively low intensity level for a sustained period of time. During the first few minutes of exercise, your body uses easily accessible *carbohydrate calories* for energy. Only after the first few minutes does your body

begin to use stored *fat calories* for energy. If your goal is to burn fat, adjust the speed and incline of the treadmill until your heart rate is near the lowest number in your training zone.

For maximum fat burning, adjust the speed and incline of the treadmill until your heart rate is near the middle number in your training zone.

## Aerobic Exercise

If your goal is to strengthen your cardiovascular system, your exercise must be “aerobic.” Aerobic exercise is activity that requires large amounts of oxygen for prolonged periods of time. This increases the demand on the heart to pump blood to the muscles, and on the lungs to oxygenate the blood. For aerobic exercise, adjust the speed and incline of the treadmill until your heart rate is near the highest number in your training zone.

## WORKOUT GUIDELINES

Each workout should include the following three parts:

**A Warm-up**—Start each workout with 5 to 10 minutes of stretching and light exercise. A proper warm-up increases your body temperature, heart rate and circulation in preparation for exercise.

**Training Zone Exercise**—After warming up, increase the intensity of your exercise until your pulse is in your training zone for 20 to 60 minutes. (During the first few weeks of your exercise program, do not keep your pulse in your training zone for longer than 20 minutes.) Breathe regularly and deeply as you exercise—never hold your breath.

**A Cool-down**—Finish each workout with 5 to 10 minutes of stretching to cool down. This will increase the flexibility of your muscles and will help prevent post-exercise problems.

## EXERCISE FREQUENCY

To maintain or improve your condition, complete three workouts each week, with at least one day of rest between workouts. After a few months, you may complete up to five workouts each week if desired. The key to success is to make exercise a regular and enjoyable part of your everyday life.

# PART IDENTIFICATION CHART

Remove this chart and use it to identify small parts during assembly. Save this chart and the EXPLODED DRAWING/PART LIST for future reference.

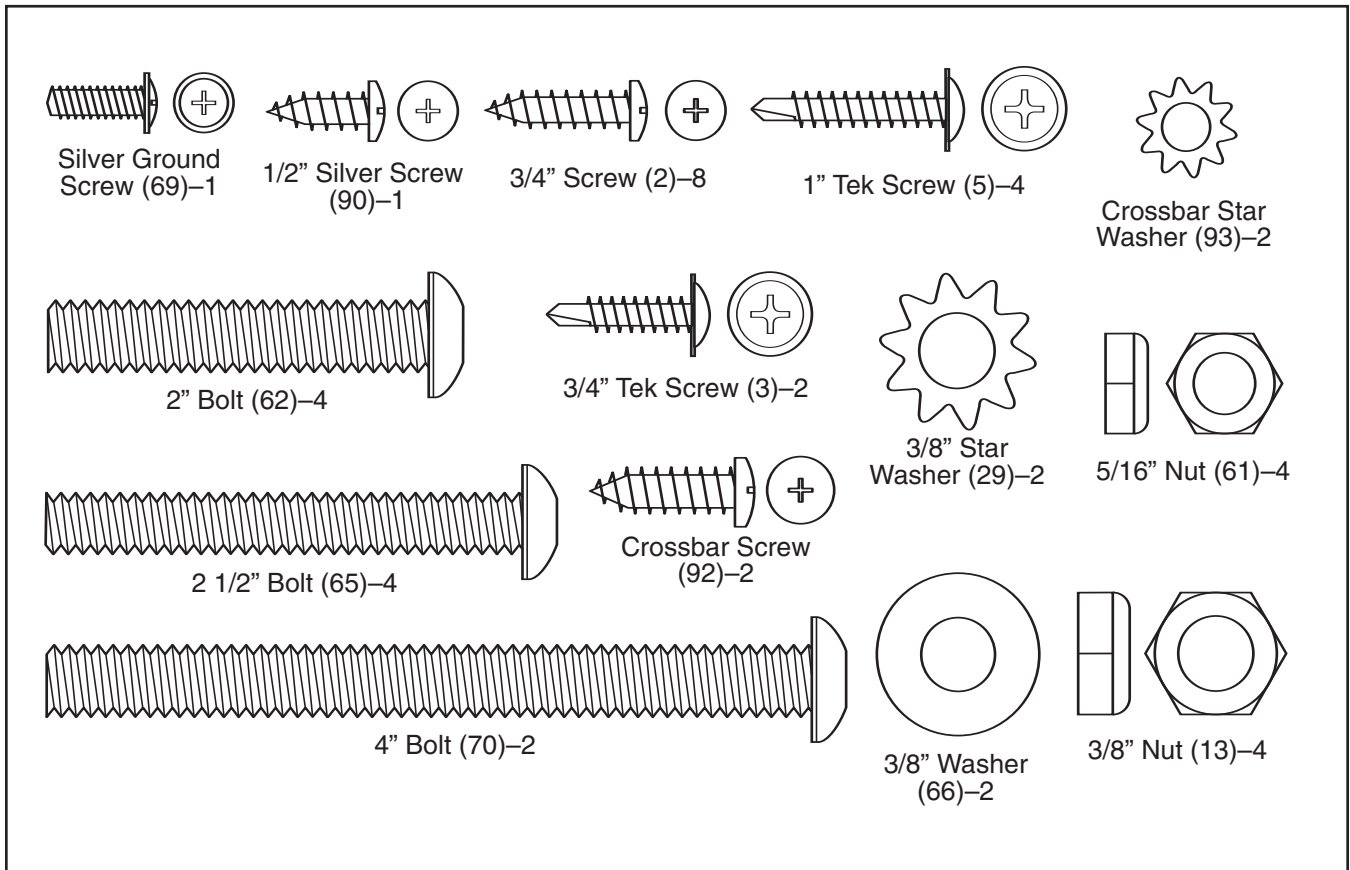

# PART LIST—Model No. WATL27105.1

R1105A

Key No.	Qty.	Description	Key No.	Qty.	Description
1	1	Motor Hood	55	1	Console
2	14	3/4" Screw	56	1	Motor Pivot Nut
3	18	3/4" Tek Screw	57	2	Handrail Foam
4	5	8" Cable Tie	58	1	Belly Pan Grommet
5	4	1" Tek Screw	59	1	Right Handrail
6	1	Warning Decal, Console	60	1	Wire Harness
7	3	Cable Tie Clamp	61	4	5/16" Nut
8	2	Foot Rail	62	4	2" Bolt
9	4	Isolator	63	4	Base Pad
10	4	Front Platform Screw	64	1	Hex Key
11	3	Rear Roller Star Washer	65	4	2 1/2" Bolt
12	2	Incline Leg Washer	66	2	3/8" Washer
13	3	Wheel Nut	67	1	Flywheel
14	2	Belt Guide	68	2	Wheel
15	4	Belt Guide Screw	69	1	Silver Ground Screw
16	1	Reed Switch Clip	70	2	4" Bolt
17	1	Motor Fan Housing	71	2	Plastic Bushing
18	2	Hood Anchor	72	1	Walking Belt
19	1	Drive Motor	73	1	Belly Pan
20	3	Wire Tie	74	1	Walking Board
21	2	Frame U-nut	75	1	Large Warning Decal
22	2	Motor Tension Bolt	76	1	Reed Switch/Sensor Wire
23	1	Motor Isolator Plate	77	1	Drive Roller/Pulley
24	1	Motor Star Washer	78	2	Drive Motor Bolt
25	2	Motor Tension Nut	79	1	Frame
26	1	Motor Pivot Bolt	80	2	Incline Pin
27	2	Frame Spacer	81	2	Incline Leg
28	4	Hood Screw	82	2	Incline Leg Cap
29	2	3/8" Star Washer	83	1	Right Endcap
30	1	Power Cord	84	1	#8 Star Washer
31	1	Controller	85	1	Rear Roller
32	12	Electronic Screw	86	1	Transformer
33	1	Filter	87	2	Rear Platform Screw
34	2	Bracket Grommet	88	4	1/2" Screw
35	1	Electronics Bracket	89	1	Book Holder
36	1	On/Off Switch	90	1	1/2" Silver Screw
37	1	Circuit Breaker	91	1	Crossbar
38	9	Roller Adjustment Washer	92	2	Crossbar Screw
39	1	Front Roller Adjustment Bolt	93	2	Crossbar Star Washer
40	2	Plastic Fastener	94	1	Pulse Wire Harness
41	1	Motor Belt	#	1	4" Green/Yellow Wire
42	1	Receptical	#	1	8" Red Wire, M/F
43	2	Rear Roller Adjustment Bolt	#	1	6" Black Wire, M/F
44	1	Latch Pin Assembly	#	1	12" Blue Wire, 2F
45	4	Pulse Sensor Assembly	#	1	6" Blue Wire, M/F
46	1	Base	#	1	8" Blue Wire, 2F
47	1	Magnet	#	1	4" Black Wire, 2F
48	1	Latch Housing	#	1	8" White Wire, 2F
49	1	Left Endcap	#	1	8" Green/Yellow Wire, F/Ring
50	1	Motor Bracket	#	1	10" Green/Yellow Wire, F/Ring
51	1	Key/Clip	#	1	User's Manual
52	1	Console Base			
53	1	Left Handrail			
54	1	Wire Cover			

Note: "#" indicates a non-illustrated part.

Specifications are subject to change without notice. See the back cover of the user's manual for information about ordering replacement parts.

# EXPLODED DRAWING—Model No. WATL27105.1

R1105A

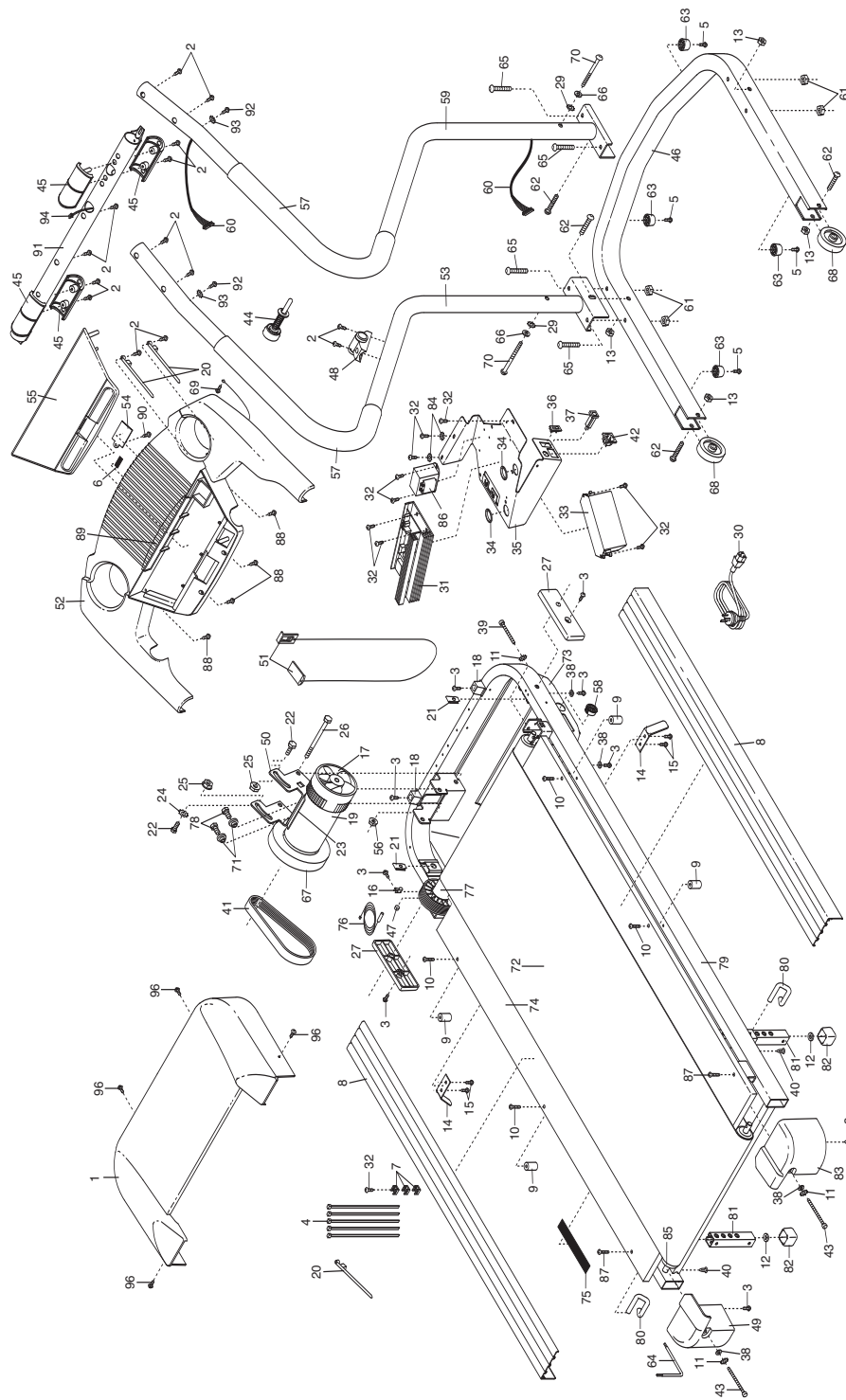



---

# HOW TO ORDER REPLACEMENT PARTS

To order replacement parts, contact our Customer Service Department or write:

Shanghai Newlife Fitness Equipment, Inc.  
Customer Service Department  
Room 504, No. 16, Lane 1030  
YanAn West Road  
Shanghai, 200052, PR China

Tel: **800-820-0915**

Before calling, please note the following information:

- the MODEL NUMBER of the product (WATL27105.1)
- the NAME of the product (WESLO E-20 treadmill)
- the SERIAL NUMBER of the product (see the front cover of this manual)
- the KEY NUMBER AND DESCRIPTION OF THE PART(S) (see the EXPLODED DRAWING and the PART LIST attached in the centre of this manual)

## LIMITED WARRANTY

Shanghai Newlife Fitness Equipment, Inc. (Newlife), warrants this product to be free from defects in workmanship and material under normal use and service conditions. The drive motor is warranted for five (5) years after the date of purchase. Parts and labor are warranted for one (1) year after the date of purchase.

This warranty extends only to the original purchaser. Newlife's obligation under this warranty is limited to replacing or repairing, at Newlife's option, the product through one of its authorized service centers. All repairs for which warranty claims are made must be pre-authorized by Newlife. This warranty does not extend to any product or damage to a product caused by or attributable to freight damage, abuse, misuse, improper or abnormal usage or repairs not provided by an Newlife authorized service center; products used for commercial or rental purposes; or products used as store display models. No other warranty beyond that specifically set forth above is authorized by Newlife.

Newlife is not responsible or liable for indirect, special or consequential damages arising out of or in connection with the use or performance of the product or damages with respect to any economic loss, loss of property, loss of revenues or profits, loss of enjoyment or use, costs of removal or installation or other consequential damages of whatsoever nature. Some states do not allow the exclusion or limitation of incidental or consequential damages. Accordingly, the above limitation may not apply to you.

The warranty extended hereunder is in lieu of any and all other warranties and any implied warranties of merchantability or fitness for a particular purpose is limited in its scope and duration to the terms set forth herein. Some states do not allow limitations on how long an implied warranty lasts. Accordingly, the above limitation may not apply to you.

This warranty gives you specific legal rights. You may also have other rights which vary from state to state.

**Shanghai Newlife Fitness Equipment, Inc.**